

MODERN GREEN DISTRICTS
**MERWEDE
UTRECHT (NL)**



BART CLAASSEN

BURA

UTRECHT



UTRECHT

- Relatively fastest growing city
- + 100.000 inhabitants by 2040

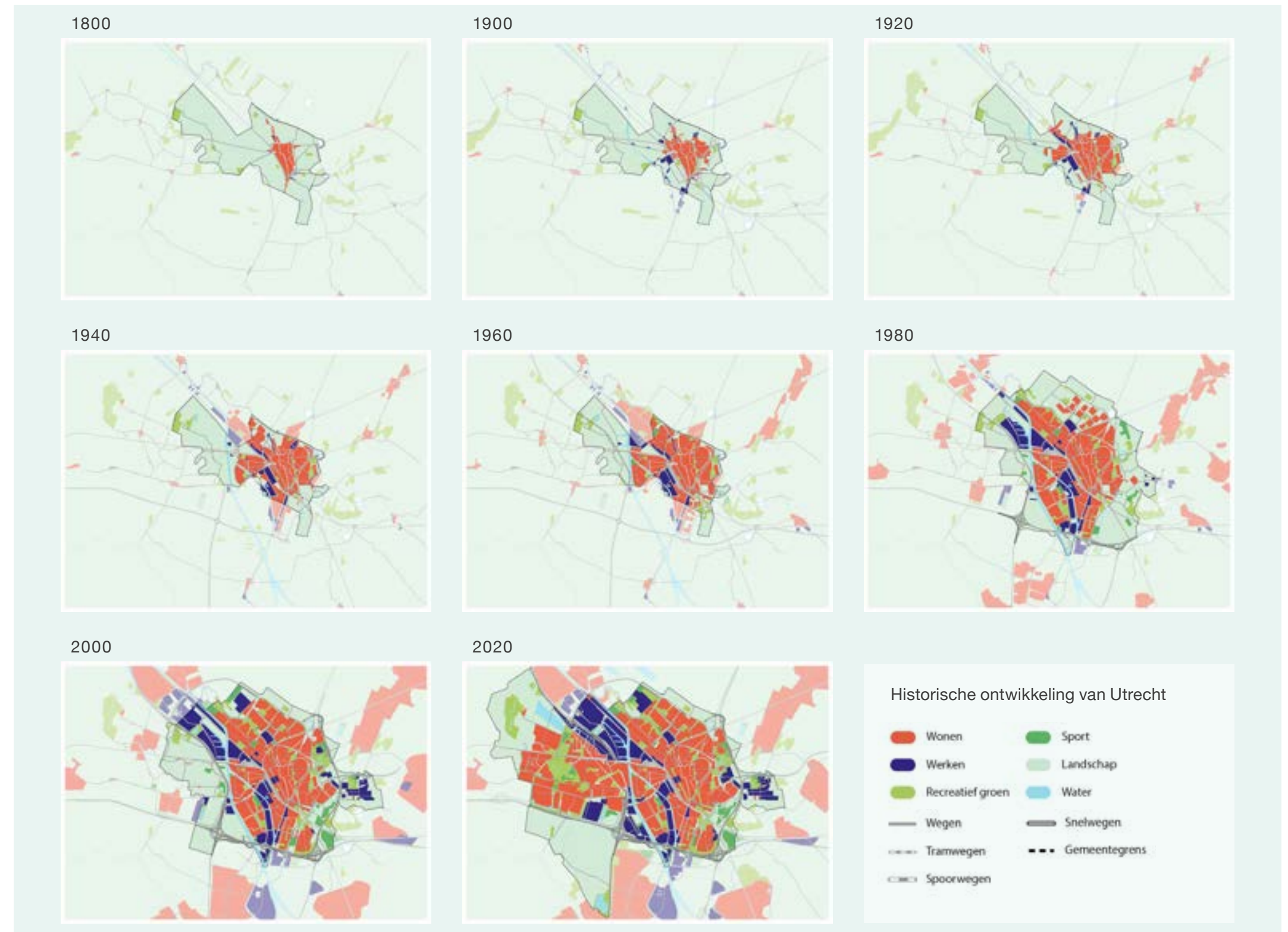

COMPACT (10 MINUTE) CITY

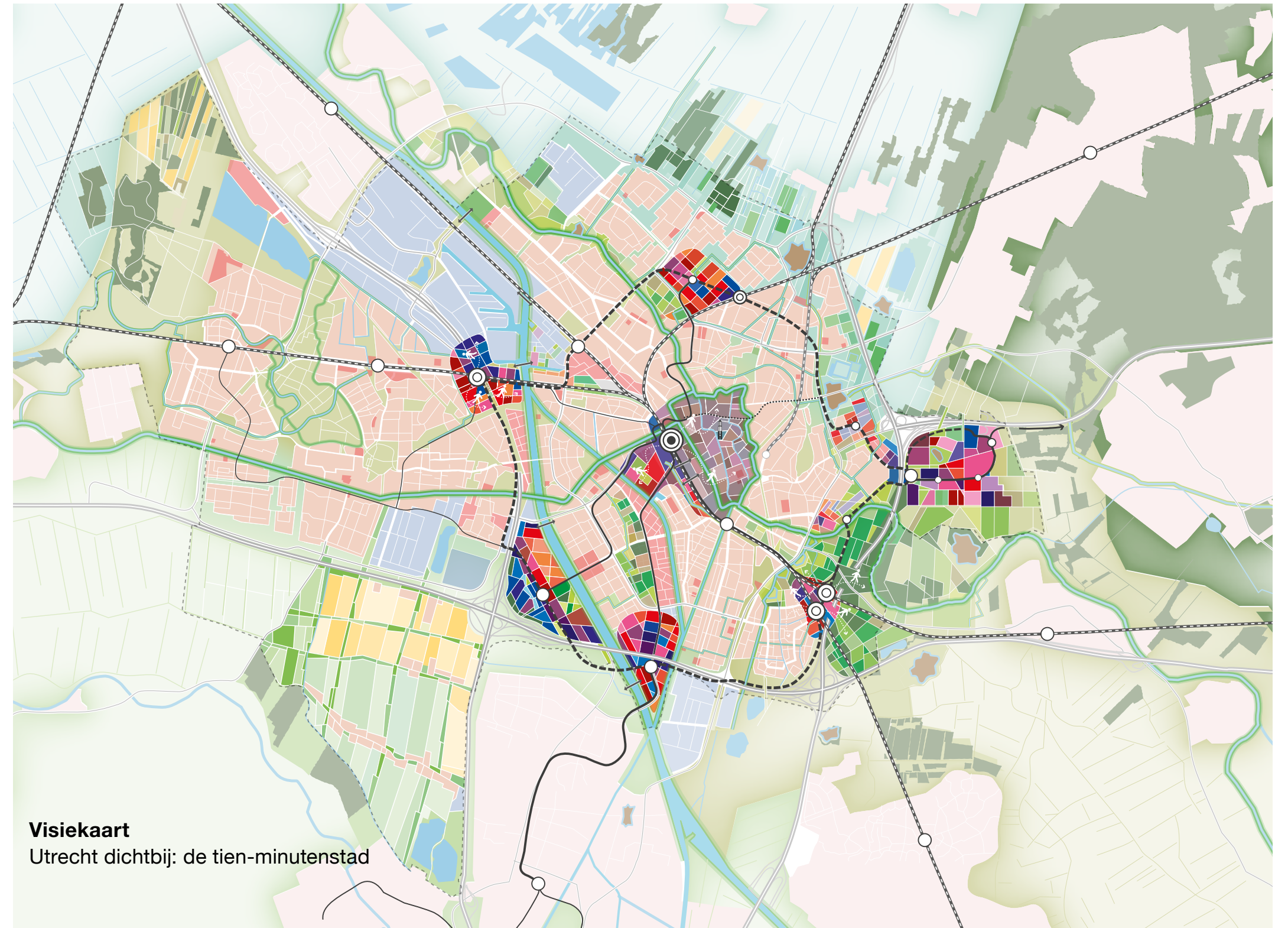

BARCODE FOR DEVELOPMENT

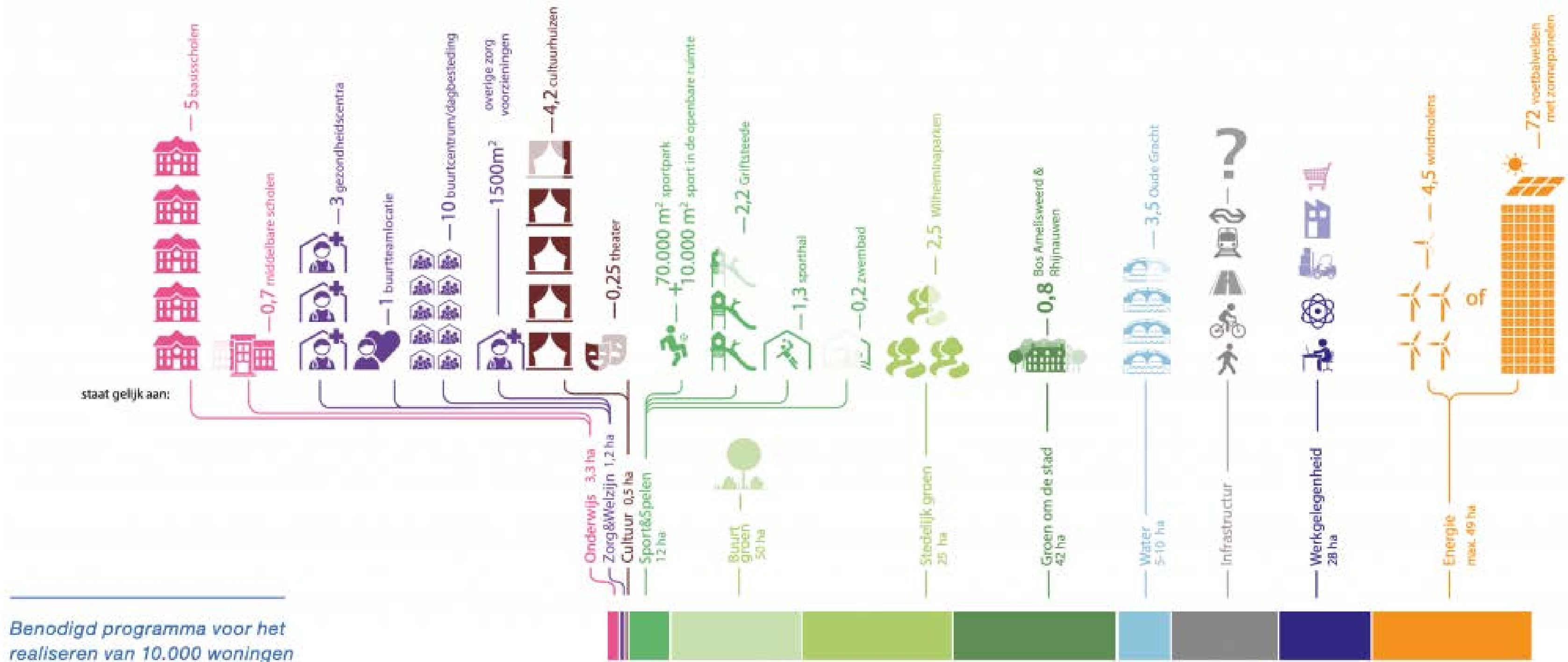

Benodigd programma voor het realiseren van 10.000 woningen

MERWEDE, UTRECHT

Merwede (5)

- 6.000 houses
- 10 minute city
- Climate adaptive
- Sustainable

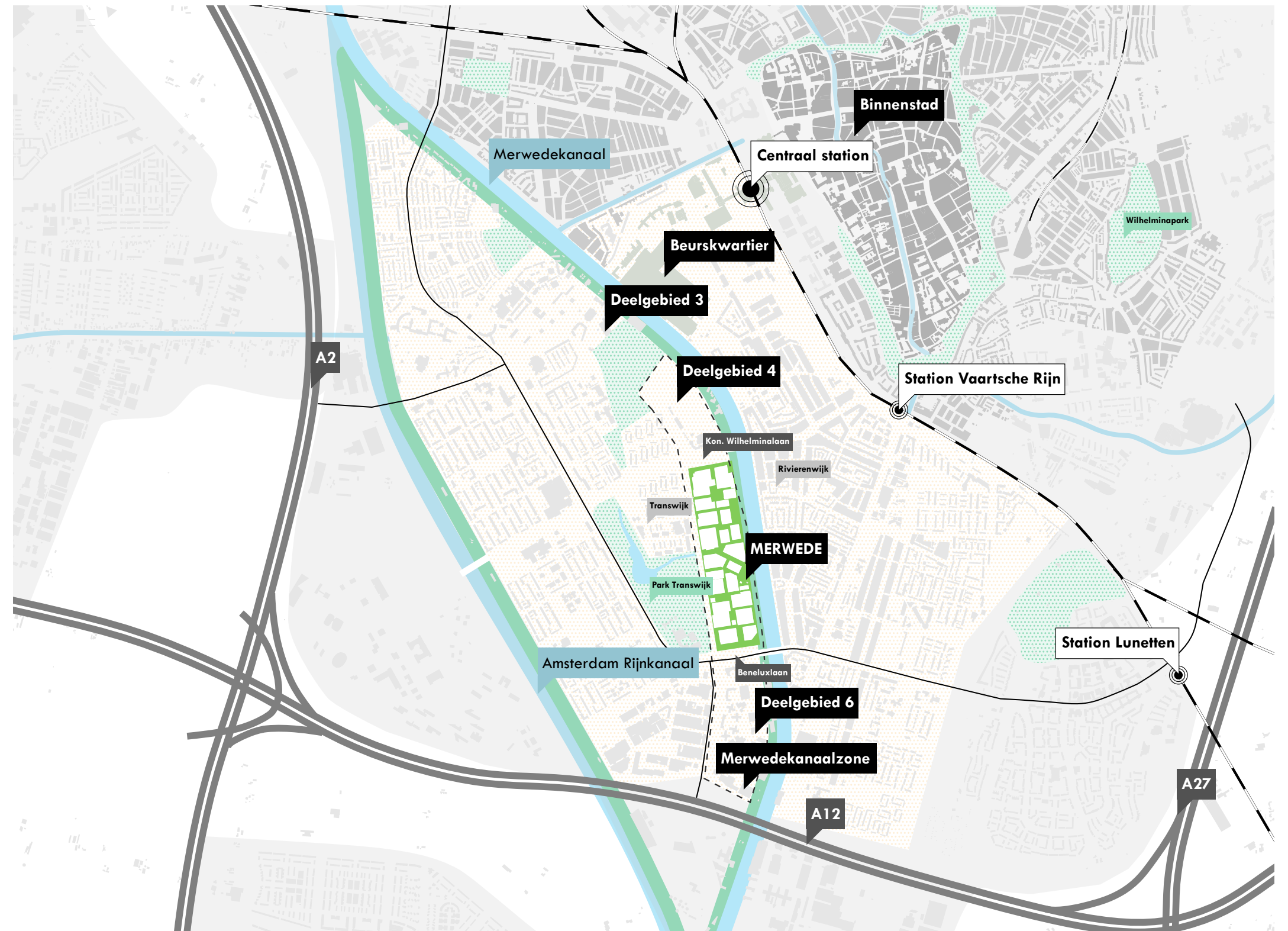

MERWEDE





2012



2016



2018

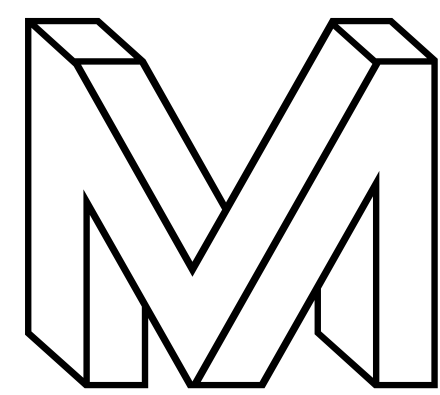

2022



COLLABORATION

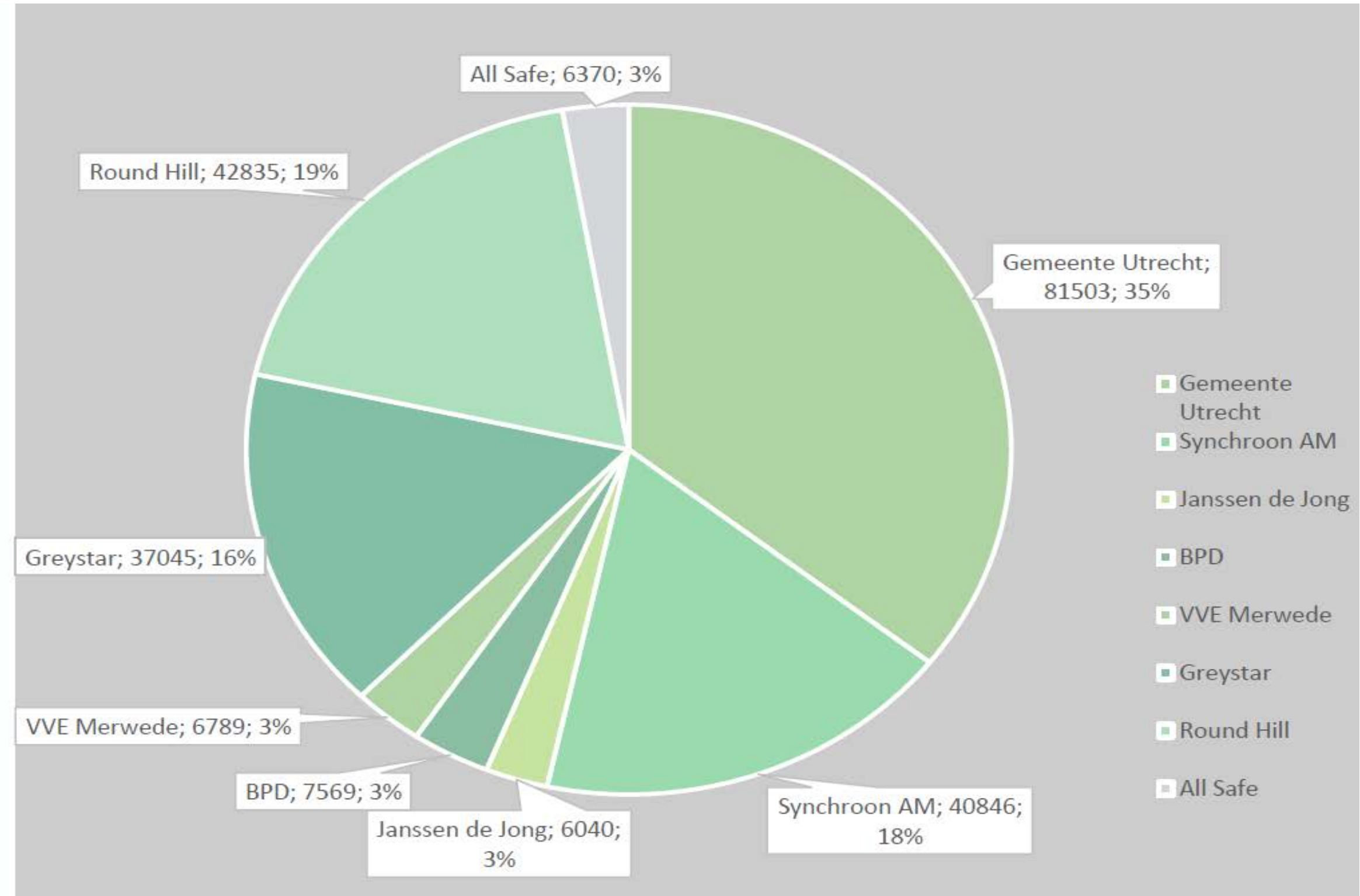
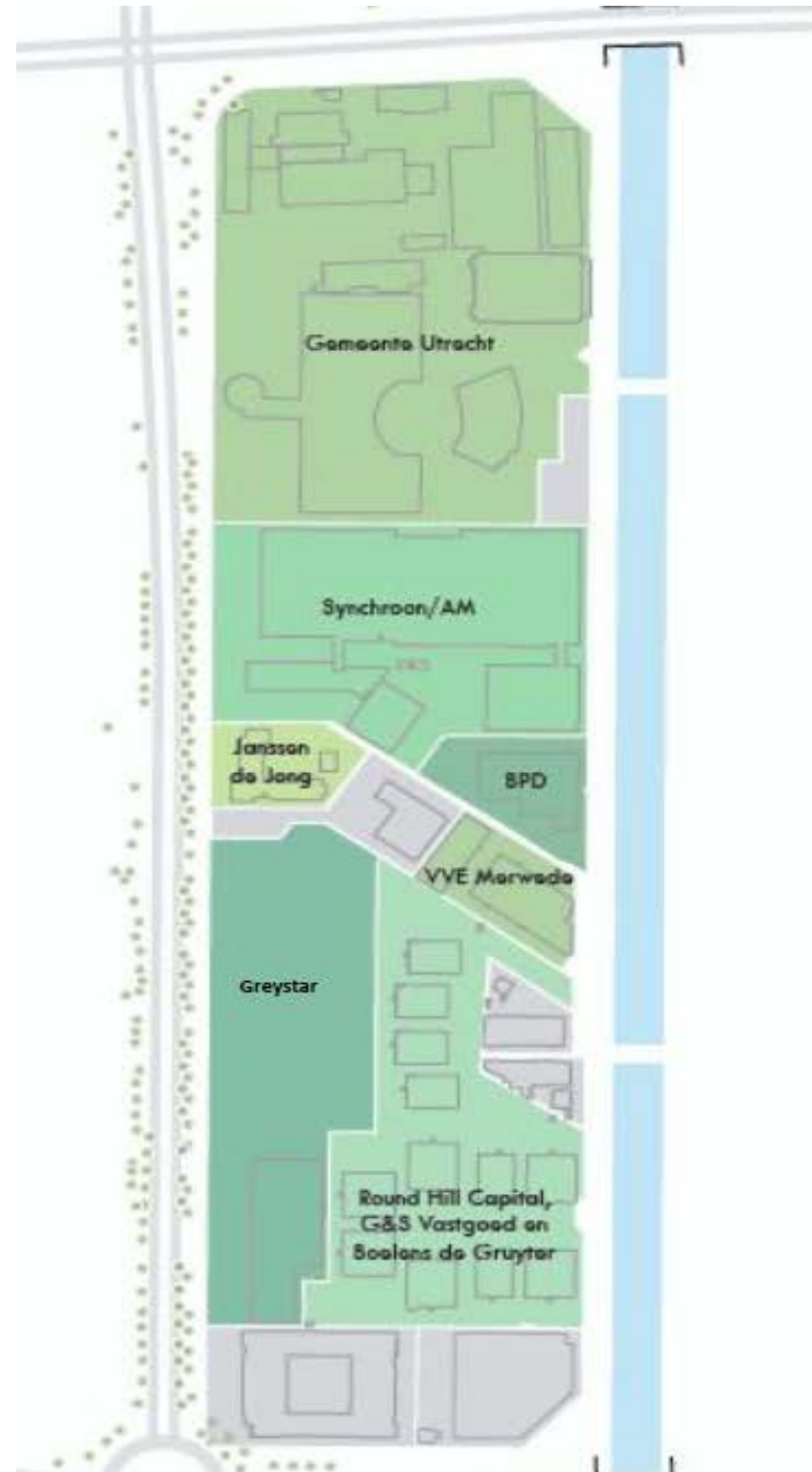

MASTERPLAN MERWEDE



Opdrachtgever: Eigenarencollectief Merwede; Gemeente Utrecht, Greystar, AM, Synchron, Lingotto, Janssen de Jong, BPD Ontwikkeling, G&S Vastgoed, Round Hill Capital, 3T Vastgoed en Boelens de Gruyter

Ontwerp: BURA urbanism met Gemeente Utrecht, Stadkwadraat, LOLA Landschapsarchitecten, Mark Rabbie urban concepts, Goudappel Coffeng, RebelGroup, Merosch, Stratego Advies and Unchain the Tigers

Architecten: Rijnboutt, ANA, INBO, Group A, Zoetmulder, BETA, KCAP, Monk, Studio Nauta, FLUX, Venhoeven CS, MKA, Buro Harro, Mei Architecten, De Zwarte Hond

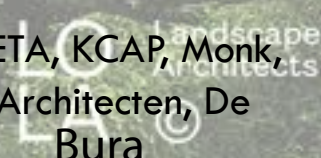

MASTERPLAN MERWEDE

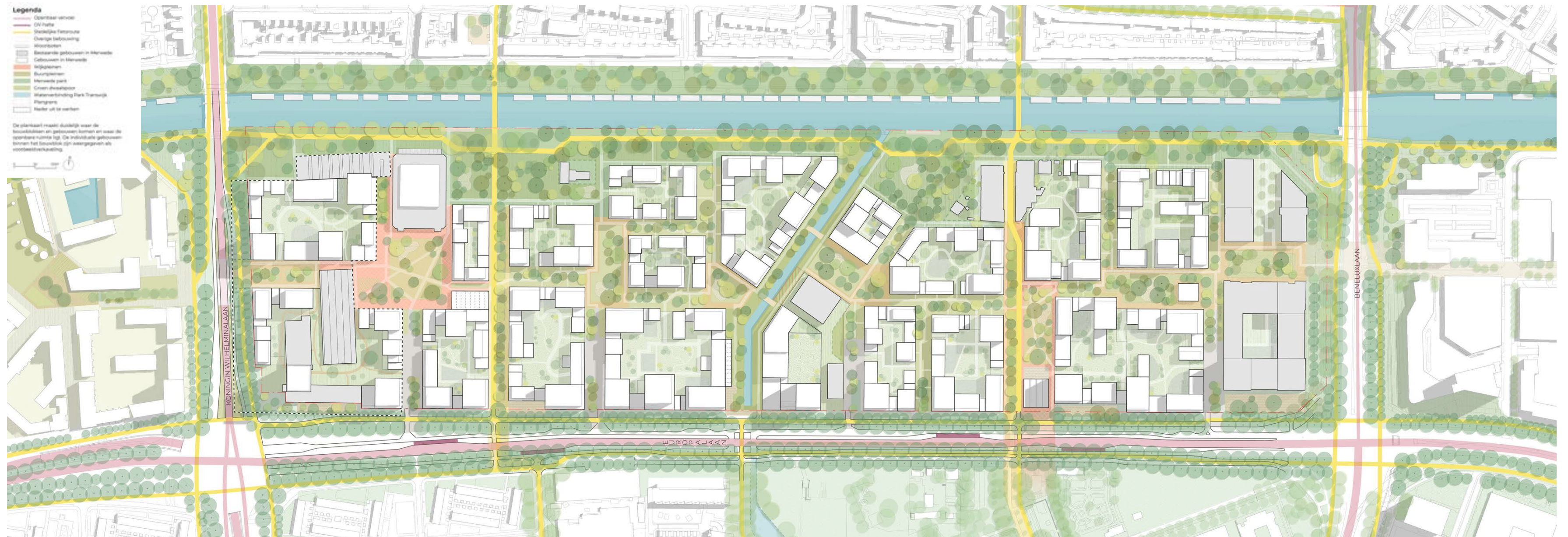

Mobile Merwede



Green unless...



Coulissestad



Healthy and sustainable



Mixed use neighborhood

COULISSESTAD

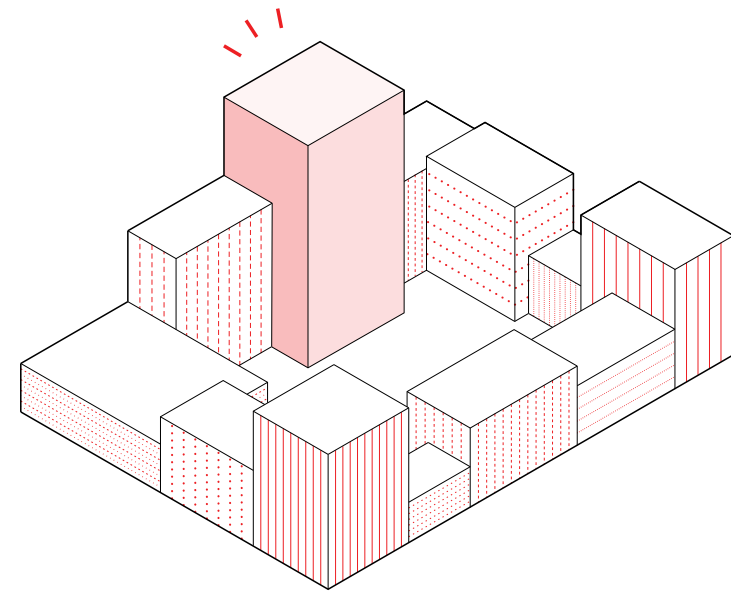

Unity in diversity

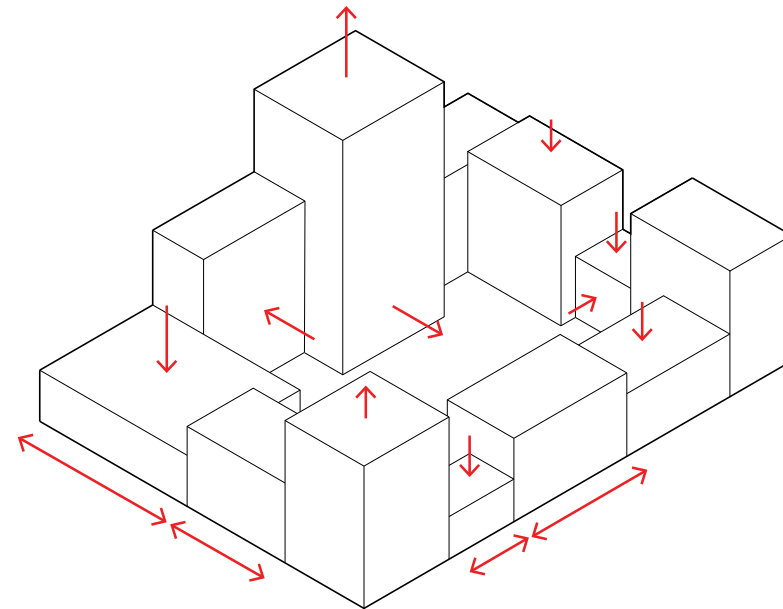

Composed with building by building

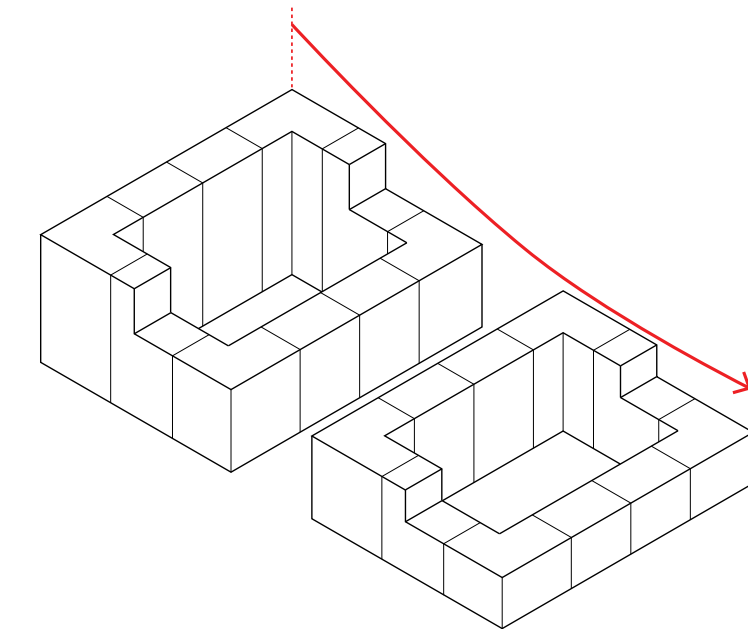

Descending density and height

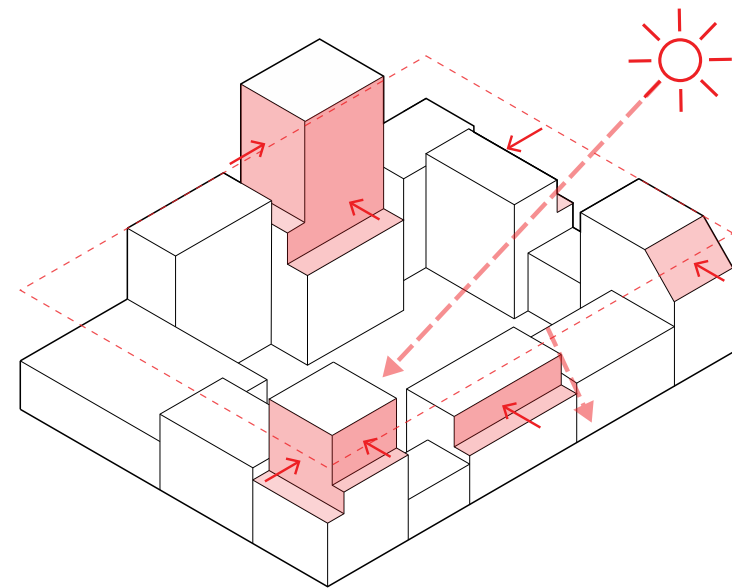

Light and air

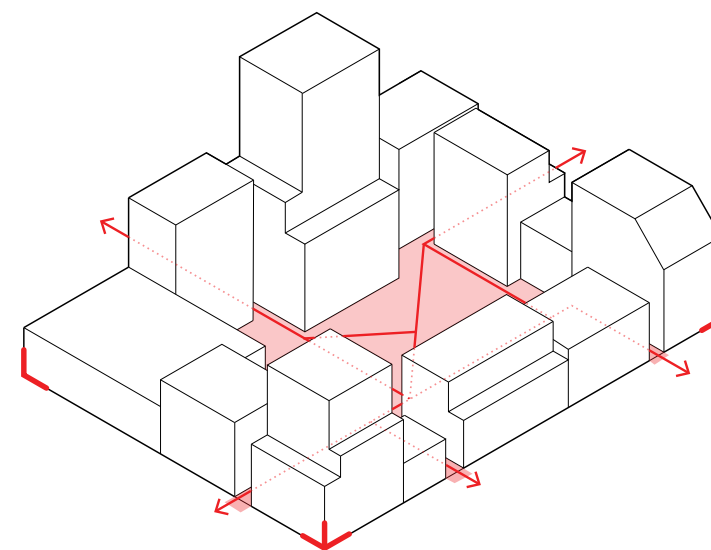

Framed and accessible

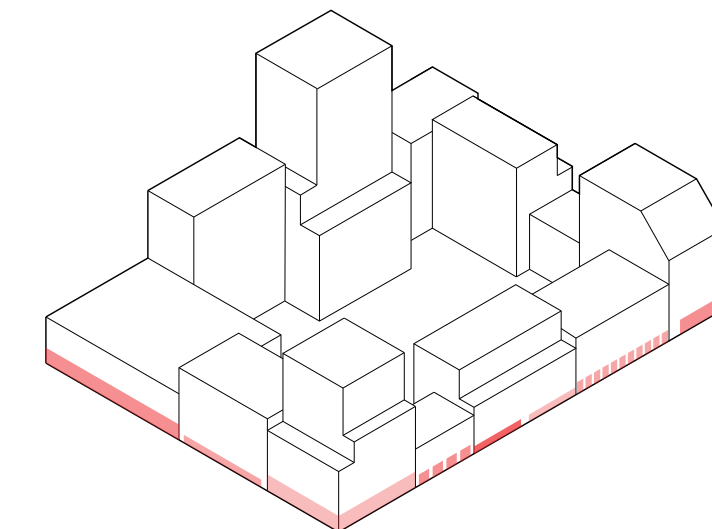

City at eye level

COULISSESTAD



@ Blok 13/14 (SO) ; Lingotto, Janssen de Jong, 3T Vastgoed / Venhoeven CS, Marc Koehler Architects

AMBITIOUS MOBILITY STRATEGY

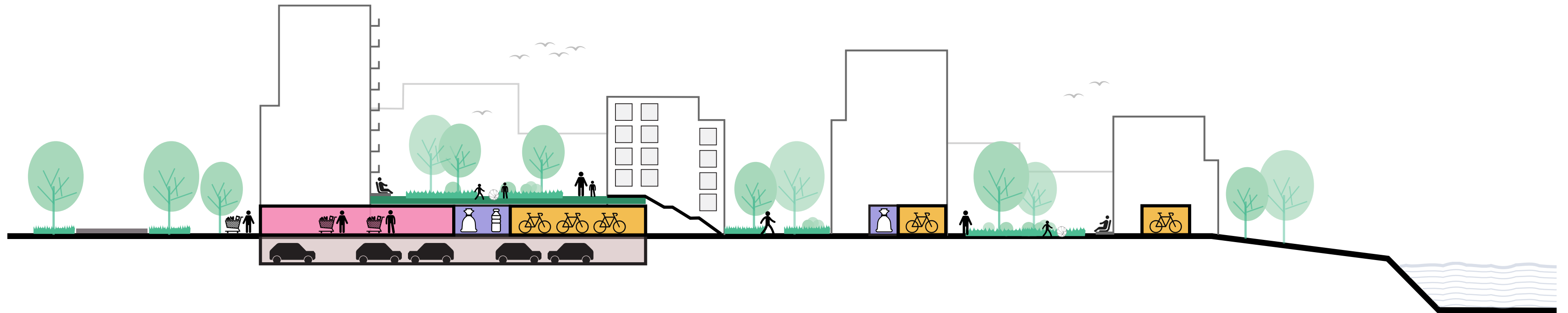

Principles:

- Carfree interior
- Parking norm 0,3 (HUBs) + 250 shared cars
- Clustered logistics & innovative waste collection
- Intricate bike and pedestrian network

LOGISTICS

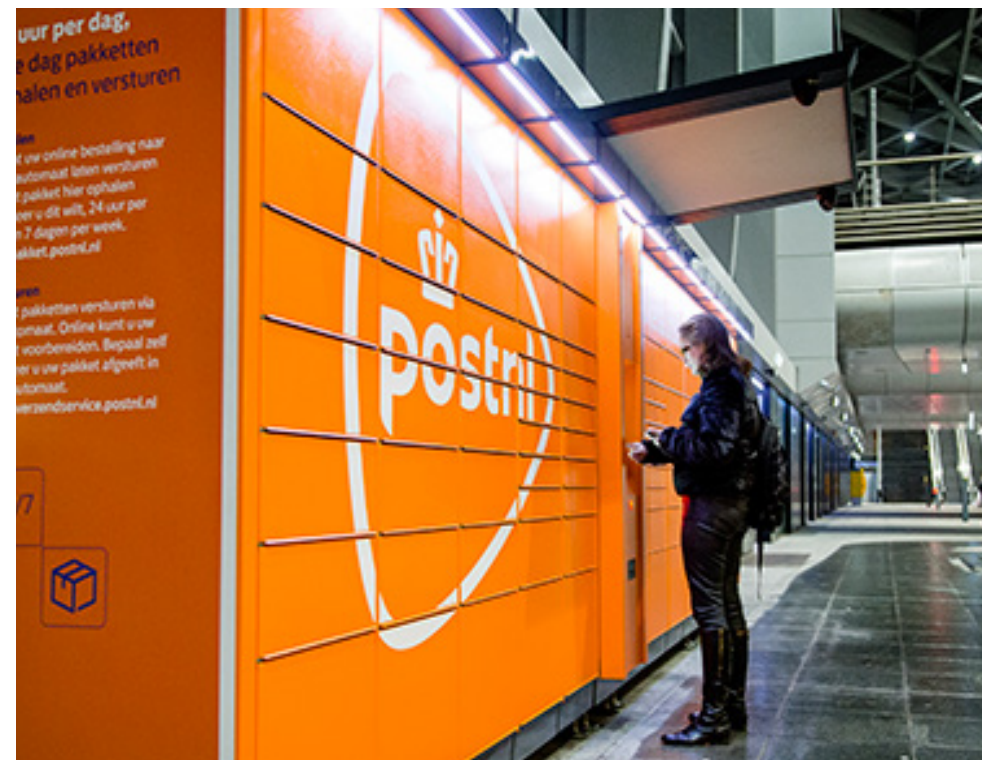
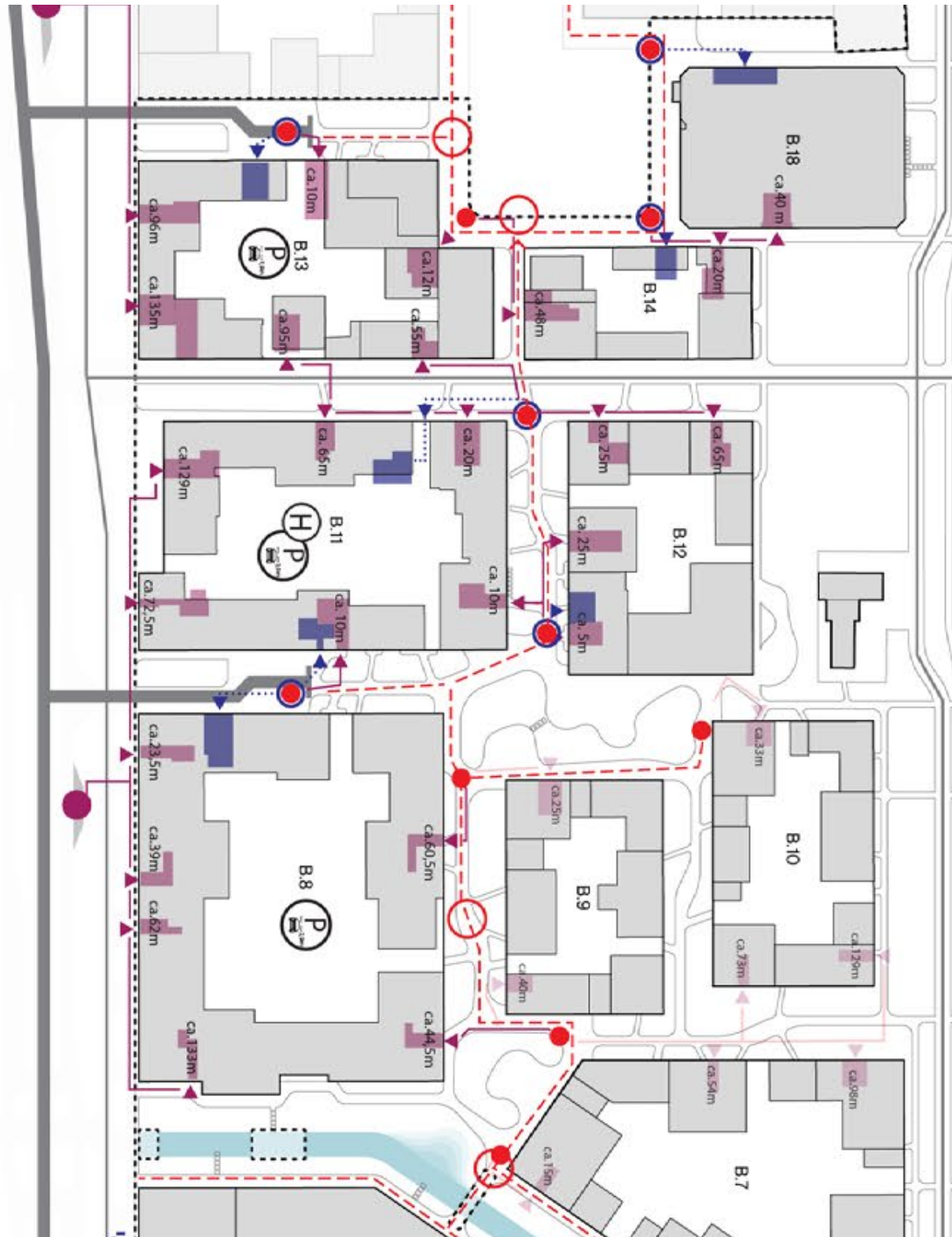

BIKE NETWORK

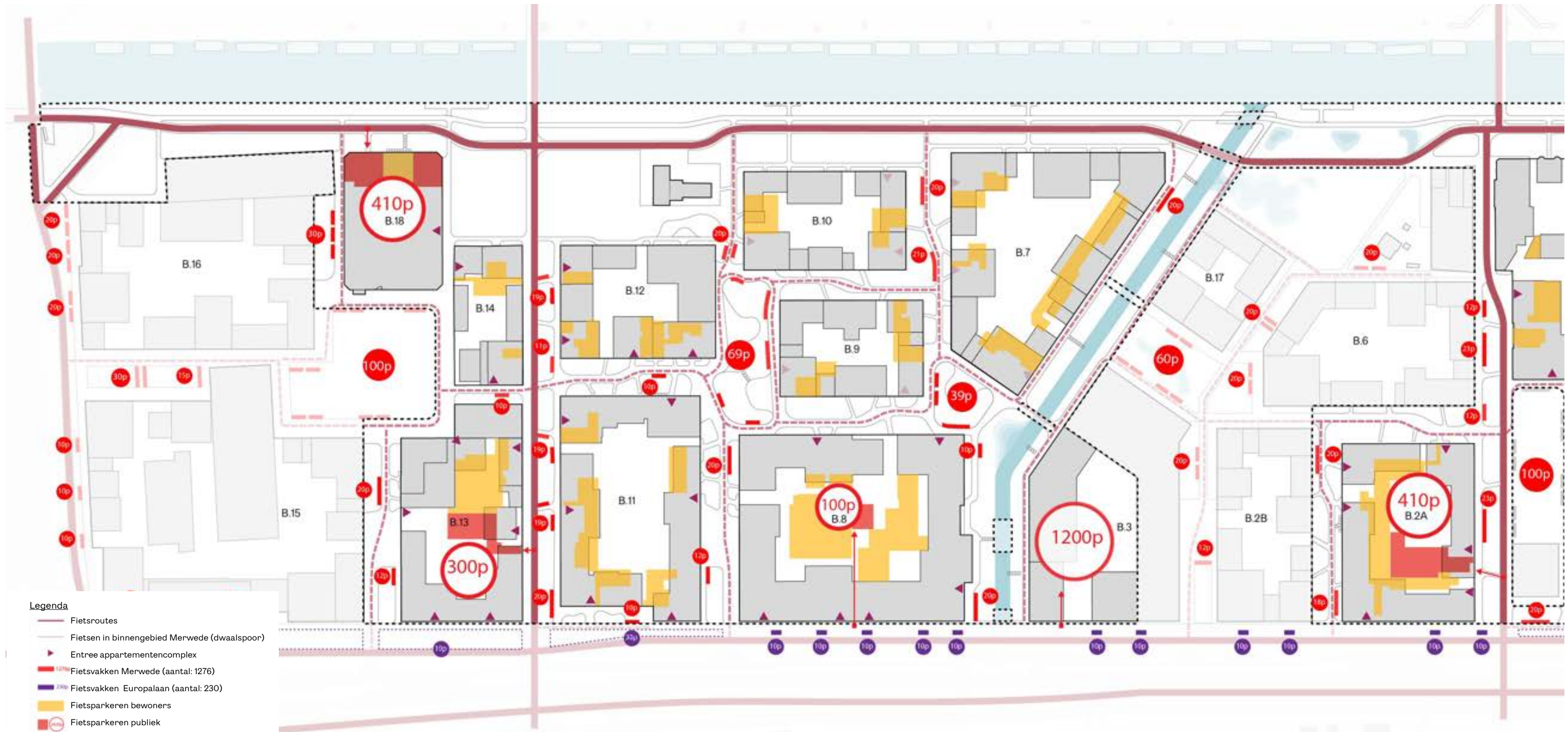



MIXED USE



SUSTAINABLE

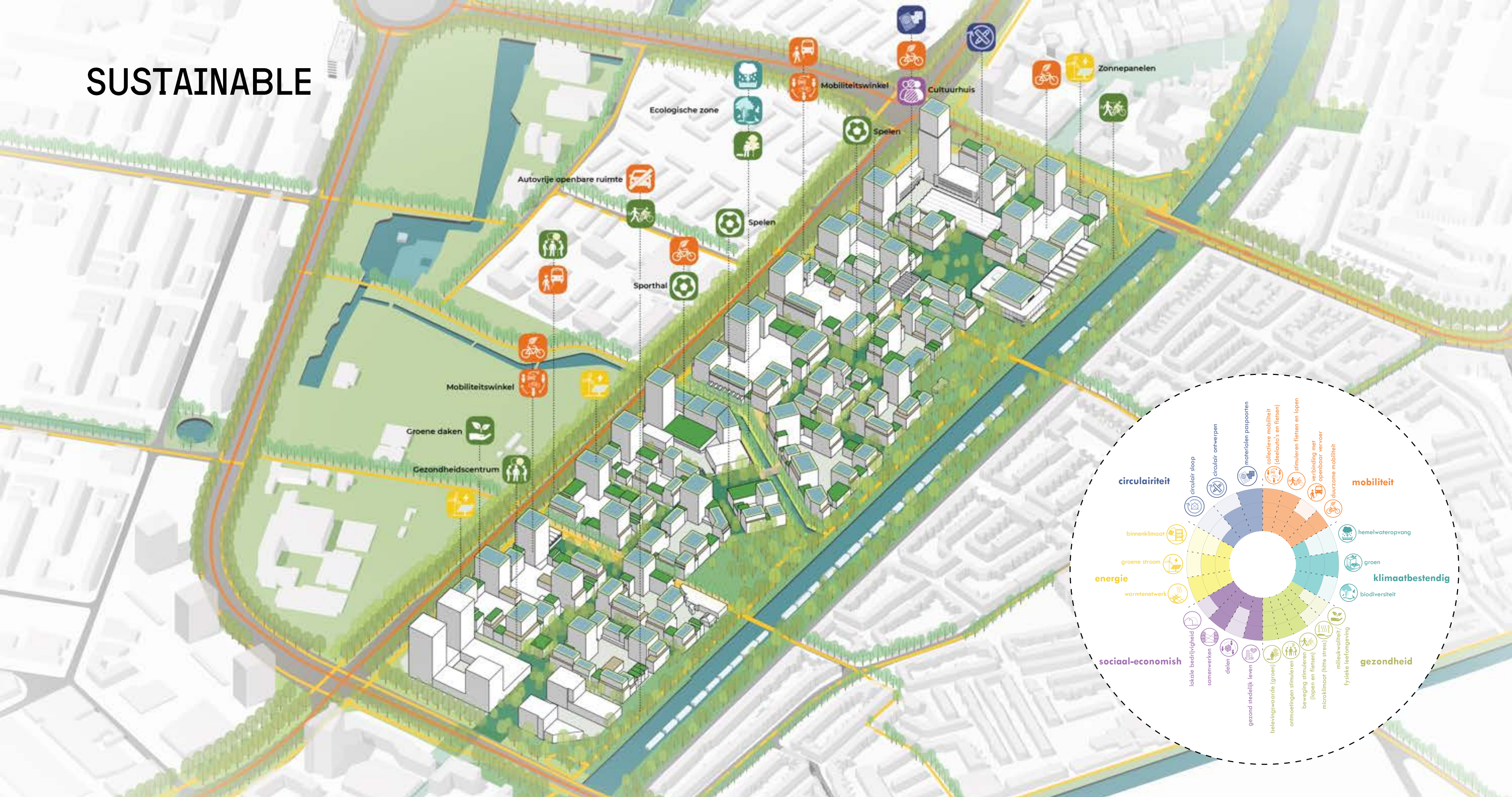

GREEN UNLESS

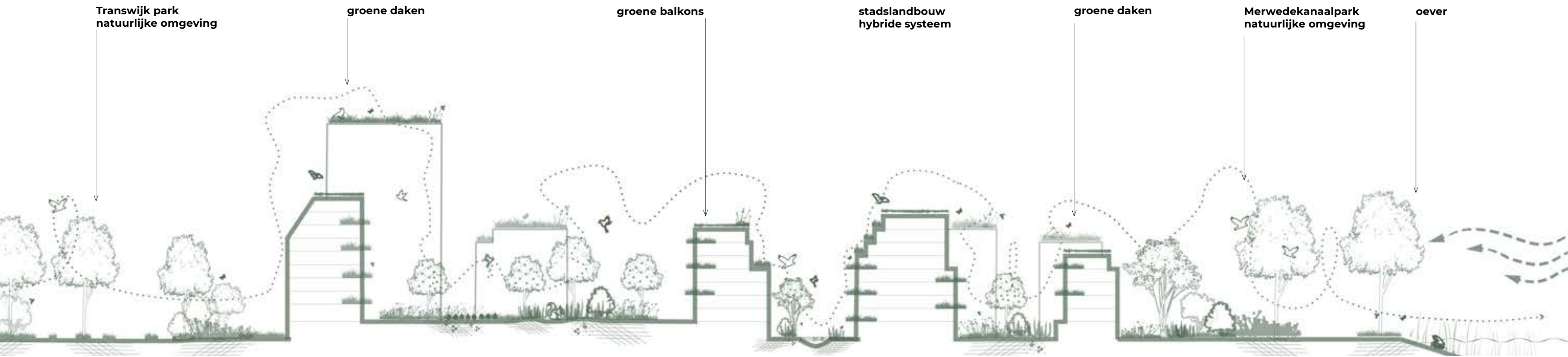

Park Transwijk

Groene daken

Binnentuinen

Pleinen

Dwaalspoor

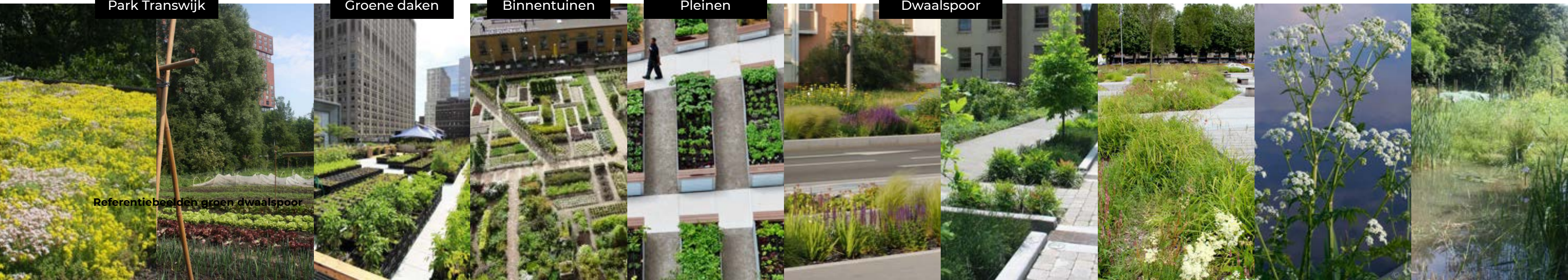

GREEN UNLESS



LEGENDA

ALGEMEEN

- - - - - Demarcatie MERWEDE Deelgebied 05 - VOIP fase 1
- B.16 Bouwblok nummer
- Fietsparkeer suggestievelden (275 stuks binnen Deelgebied 05) (230 stuks buiten het gebied in project Europese Markt)
- Ondergrondse textielcontainer
- Wijkplein

VERHARDING

- Dwaalspoor breed
- Dwaalspoor smal
- Wandelpad Rondje Stadsland
- Halfverharding Buurtain
- Rijverharding inrijken
- Fietspad
- Fietspad Rondje Stadsland

GROEN TYPOLOGIEN

- Ecologische oever
- Merwedepark
- Dwaalspoor groen
- Buurtain
- Fietroute groen
- Stadsnis groen
- Sinusvelden

BOMEN

- Nieuwe boom - 1e grootte
- Nieuwe boom - 2e grootte
- Nieuwe boom - 3e grootte

WATER

- Merwedekanaal

SPELEN

- Kleine speelplek | ontmoetingsplek

MEUBILAIR

- Meubilair Rondje Stadsland (bank+afval)
- Meubilair Merwede (bank+afval)
- Stadsnis bank

FUNCTIES

- Voorzieningen
- Wonen
- Entrees / lobbies
- Techniek (o.a. fietsparkeer, etc.)
- Deltse stoep, geveltuinen of gevelterrassen

ECOLOGY

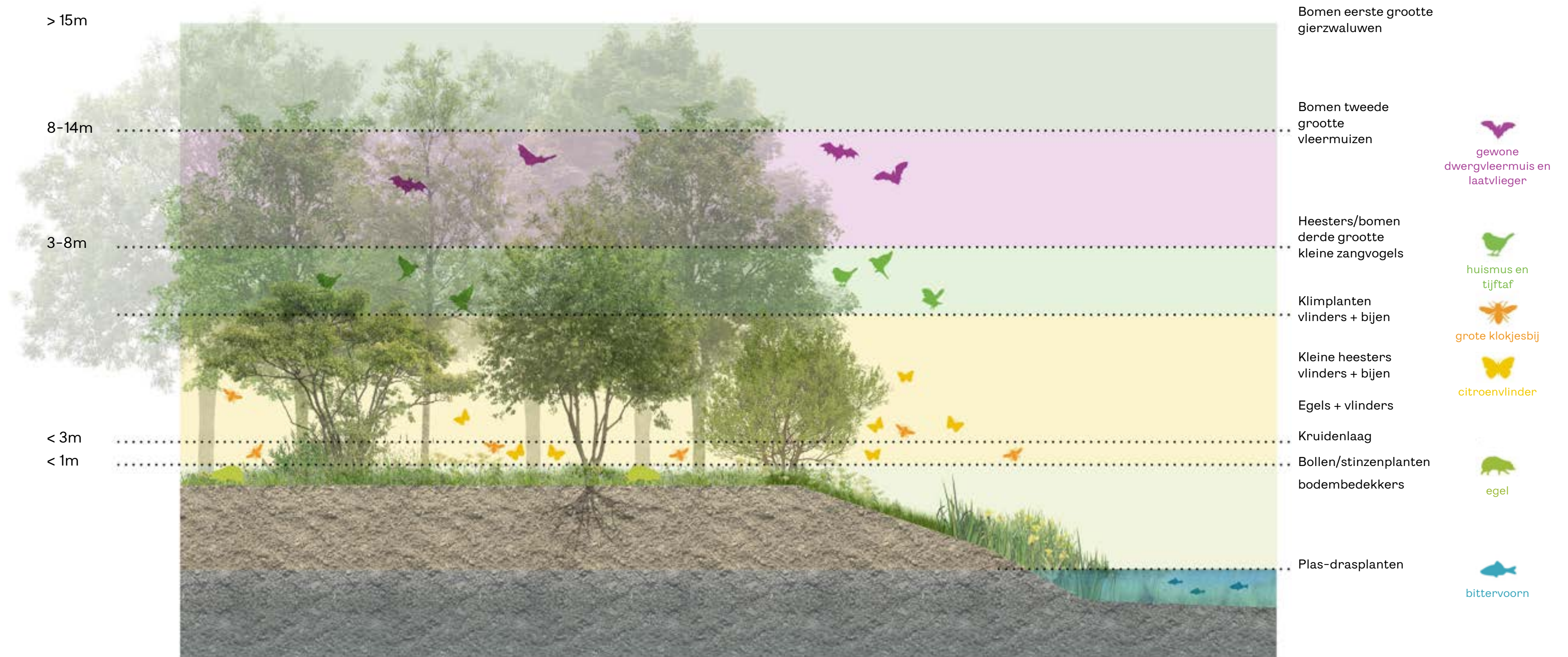

NEIGHBORHOOD SQUARE



DWAALSPOOR



MERWEDE LAB - RESEARCH BY DESIGN

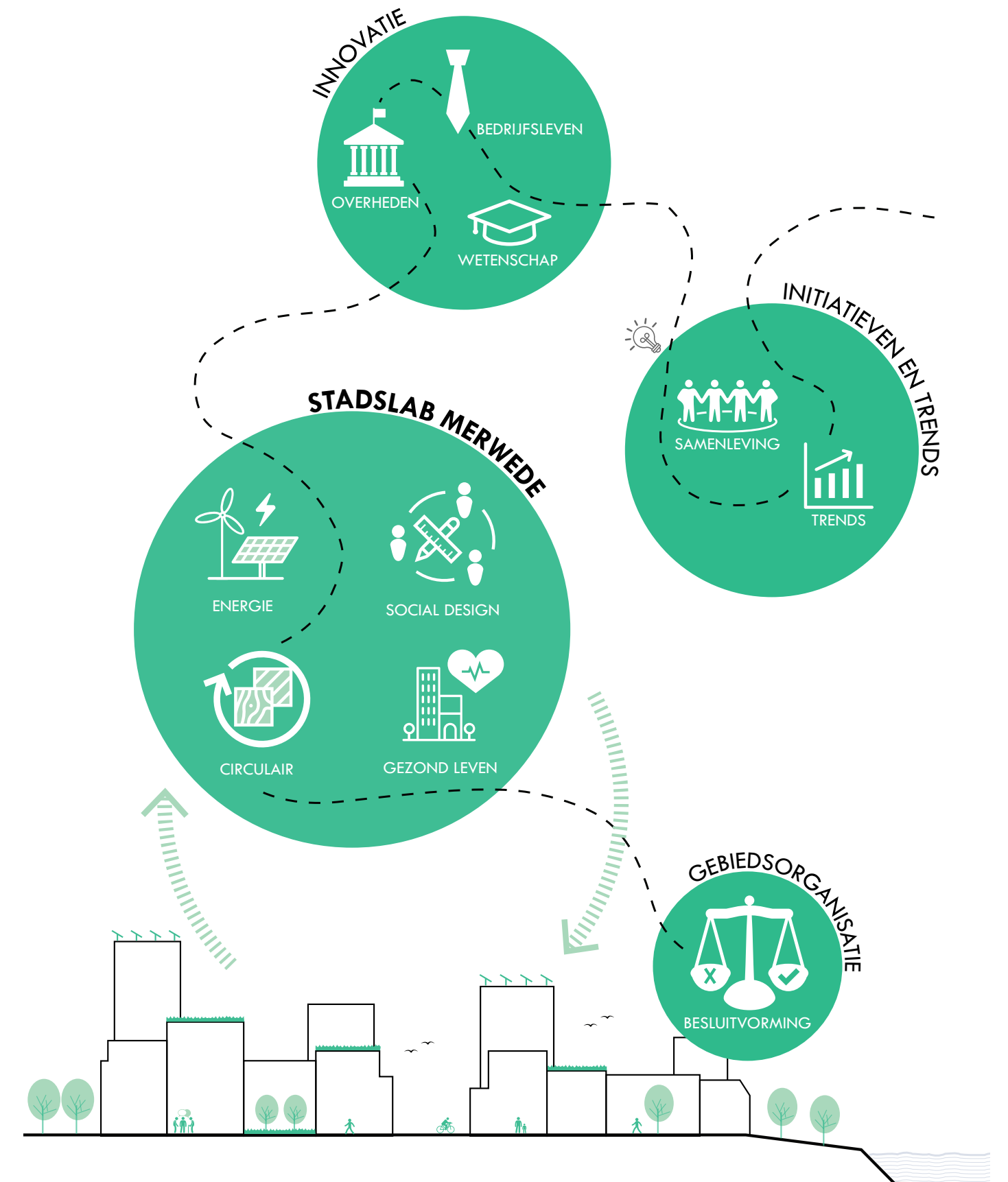

LESSONS LEARNED

Integral vision on sustainability (and mobility) from the start

Research by design (innovation and thinking outside of the box)

Public-private development was conditional for the Merwede plan

Think through the different scales

Think differently (policy, finance, governance, ...)

Stay the course!

Info: www.bura.city/merwede / www.merwede.nl